

IT Workstations for Pharma & Life Science



Serving World Leading Manufacturers



BLUE LINE
IT for Demanding Environments

How can Blue Line support you?

A partnership with Blue Line equals



Retrofit or renew current IT installation and gain higher productivity and user satisfaction. Benefit from our experience and knowledge based on numerous installations in cleanrooms and pharmaceutical manufacturing sites around the world.

Avoid worries about inspections and regulatory requirements with unique technologies keeping all IT hardware completely clean, whether it is fixed mounted or mobile solutions.

Meet all functional requirements and is in compliance with current infrastructure choosing Blue Line's modular and configurable platforms.

Modernize and optimize the workflow, as well as safety and comfort. Achieve a significant return on investment and a competitive solution with Blue Line's quality products.

COSTUMER STATEMENTS

"This simplified our installation and reduced our costs."

"Blue Line had the right hardware, which only had to be customized according to what we wanted. This meant the right IT solution at the right price."

"Blue Line was involved in the project from the start and they were available for support throughout the implementation process. Blue Line presented the optimal hardware to us, which met our requirements 100%."

"I am truly impressed. We have met a company that is ready to embrace changes, which assures product quality."

"The new Blue Line HMI with a hinged keyboard is a state-of-the-art IT hardware solution with a modern design, which looks very impressive."

LEARN MORE ABOUT BLUE LINE



Reliable Solutions for Pharma & Life Science

Blue Line provides reliable IT hardware based on your environment and needs. Blue Line's product line is compliant with all regulatory requirements in GMP, FDA, and ISO 14644, allowing you to optimize workflow, traceability, and documentation in all phases of production and packing.

WE UNDERSTAND YOUR ENVIRONMENT

Blue Line has been a global supplier of highly reliable IT solutions for demanding environments for more than 35 years. Our DNA is customer focus in all phases of the cooperation. In surveys, the majority of our clients emphasized Blue Line's ability to listen and to create solutions in close cooperation with our dedicated team.

HIGHER PRODUCTIVITY AND USER SATISFACTION

Benefit from a product range designed to avoid the typical challenges in biotech and pharmaceutical manufacturing. Renew or retrofit current IT installation and gain higher productivity and user satisfaction. Benefit from experience and knowledge based on numerous installations worldwide.

QUALITY AND RELIABILITY

All products are designed for 24/7 uptime, with low power consumption, passive cooling, and without moving parts for maximum operational reliability. All company procedures are subject to strict quality standards in the ISO 9001:2015 certification. As a company, we also hold an AAA credit rating.

Integrate large size HMI in-wall solutions. Ideal for planning and sharing of information



Meets regulatory requirements

Benefit from a product range designed to avoid the typical challenges in life science and pharmaceutical manufacturing. Avoid worries about inspections and regulatory requirements with innovative technologies keeping all products completely clean and sterile.

COMPLIANT WITH GMP – FDA – ISO 14644

Take advantage of our extensive experience with IT for cleanrooms. Blue Line's products comply with all regulatory requirements for EU GMP classification for cleanroom A-B-C-D, as well as FDA and ISO 14644.

Meets all needed regulatory requirements as GMP, FDA and ISO 14644



EASY TO CLEAN

All products are consciously designed with smooth surfaces, slanted sides, and rounded edges, meaning that products are easy to clean.

Slanted, rounded edges and smooth surfaces make it easy to clean



WITHSTANDS ALL KNOWN CLEANING DETERGENTS

Blue Line's cleanroom products withstand all known cleaning detergents such as iso-propyl alcohol, non-deionized water, VHP, Spor-Klenz™, Klercide, Actisan, LpH®, Vesphene®, and many more.

Withstands all known cleaning detergents



Easy to use

Blue Line's cleanroom HMI workstations are very easy to use and prevent compromising of regulations. Gain higher productivity and user satisfaction with the cutting-edge, auto-calibrated touch technology that works with various layers of gloves. This technology is chosen by most of the pharmaceutical manufacturers.

OPERABLE WITH GLOVES

Blue Line's cleanroom workstations support operation with gloves. A typical use case would be operation with two or three layers of gloves. The innovative touch display includes auto calibration for seamless operation and avoids interruptions in the production process.

HYGIENIC KEYBOARD

Standard keyboards are not suitable for use in cleanrooms, as dirt accumulates under the keys and trackball. Furthermore, the design and materials of most keyboards do not permit regular cleaning with aggressive agents. The surface of Blue Line's hygienic keyboard is completely flat and can be effectively disinfected with no compromises. Blue Line's touch

keyboards are without moving parts, ensuring long durability and long-term reliability. If you prefer a keyboard with keystroke, all Blue Line HMIs are also available with membrane keyboards.

Auto-calibrated touch technology operable with various layers of gloves



Completely flat hygienic touch keyboard. Easy cleanable with no compromises



Modular Design - Built to Your Needs

Blue Line's modular design makes it possible to configure the majority of HMI Workstations and Mobile Operator Stations to specific needs in functionality, finish, and environment.

Choose between different variants on the basis of casing, size, input, communication, and mounting. Discover the

possibilities below. If you do not find a combination that fits your requirements, Blue Line has a strong capability to customize

products according to your specifications.

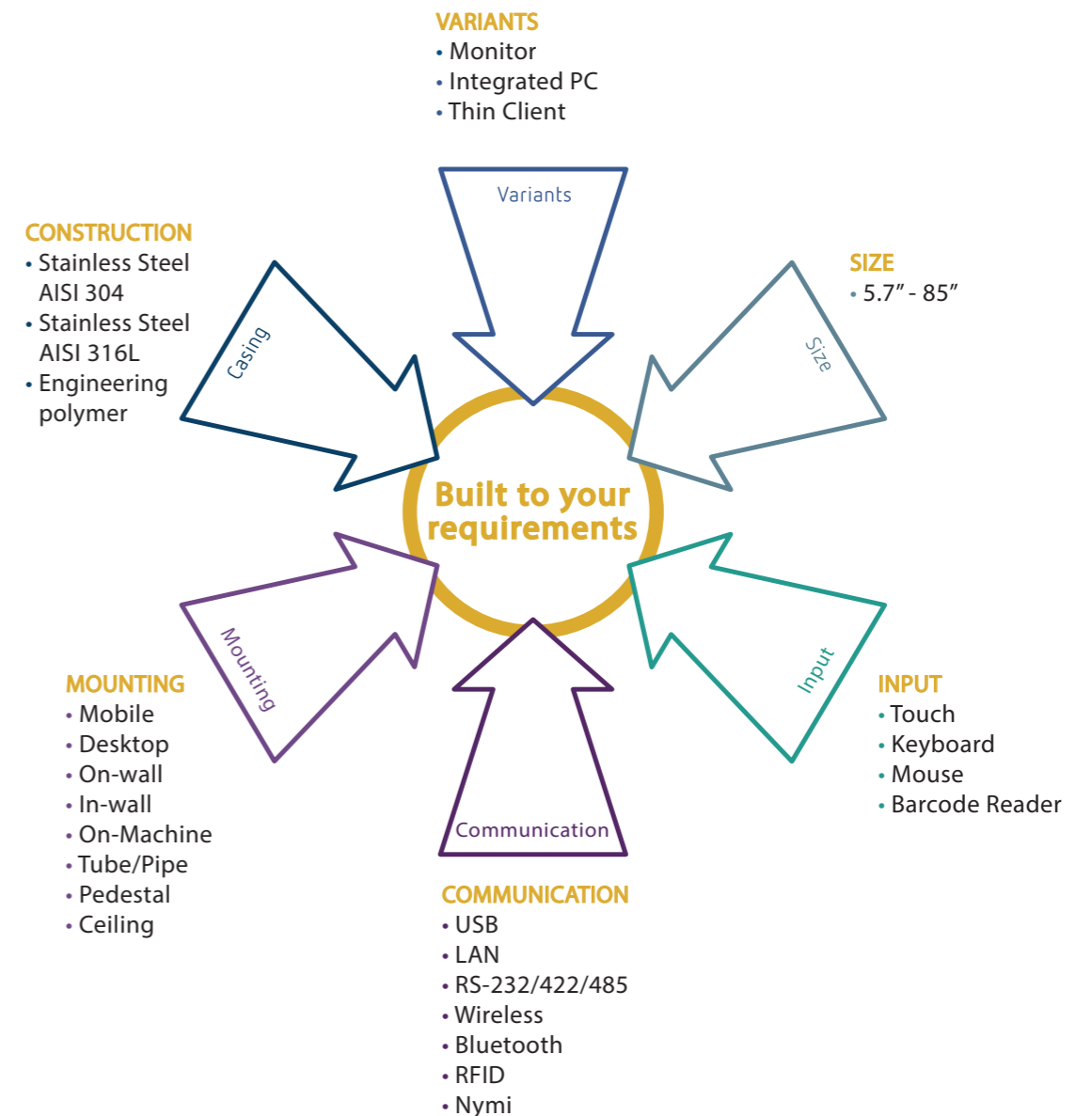

Easy to implement

Blue Line provides a wide range of flexible mounting solutions regardless of whether the mounting is to be done on the wall, floor, ceiling, desktop, or a machine. Installations can be fixed, rotating, tiltable, or even mobile. Separate or attached keyboards can be a part of the system.

The mounting solutions are designed to ensure smooth transitions between the individual components, making cleaning easy. Made entirely of stainless steel, all mounting solutions are ingress proof, withstanding tough cleaning procedures. Based on your specific needs, we are pleased

to prepare a proposal that ensures the best functionality, ergonomics, and occupies as little space as possible.

Wall or machine mounting with optional tilt and swivel

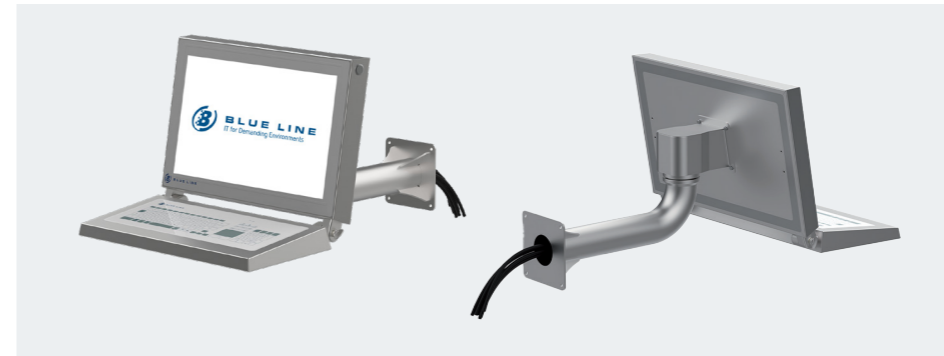

Wall mounting with tilt

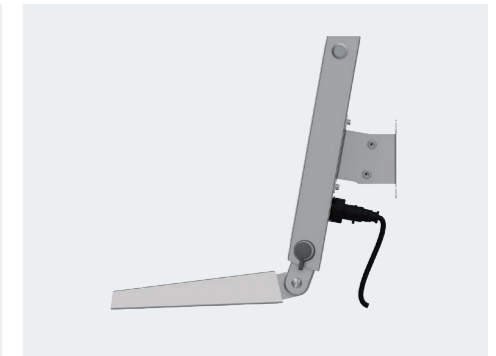

In-Wall mounting saves valuable space



Principle of mounting in the wall



Ceiling mounting with optional tilt and swivel



Pedestal or table mounting with optional tilt and swivel



HMI with integrated keyboard - table/pedestal mounting



Mobile Operator Station



Add a stainless steel sterile keyboard mounted directly on the wall



Desktop workstation



Ceiling or pedestal mounting for dual HMIs horizontal



Ceiling or pedestal mounting for dual HMIs vertical



Mobility increases productivity

Do you find that fixed mounted HMI monitors and PCs can be inflexible and cost-intensive? Then take a closer look at Blue Line's Mobile Operator Stations and achieve greater productivity. Reduce both installation and manufacturing costs and obtain a flexible position for shifts in production types and batches.

MEETS GMP, FDA AND ISO 14644 REQUIREMENTS

Mobile Operator Station T3000 is compliant with all regulatory requirements. Designed to meet the EU CGMP and ISO 14644 classifications for cleanroom. Withstands all known cleaning detergents.

WORK MOBILE 24/7

Blue Line's mobile operator stations come with hygienic casters and can be moved around where needed, always ready for use when needed. Powered by either AC or integrated batteries. Benefit from a battery capacity to work unplugged for an entire shift.

When capacity decreases, then simply hot swap the batteries without turning off the system and achieve seamless continuous production. Batteries charge via the integrated charger or external battery charger and secure maximum mobility.

BEST-IN-CLASS ERGONOMICS

Ergonomics can be an issue in cleanrooms, and often systems are fixed in height and angle that do not fit all users. Obtain high user satisfaction and greater productivity from Blue Line's mobile operator stations due to the stepless electric height adjustment via actuator.

Both seated and standing operation are supported. On some models, you can also swivel and tilt the display.

EQUIP WITH HMI, MONITOR, PC, THIN CLIENT, SCANNER, KEYBOARD/MOUSE, ETC.

Configure with the IT needed for your production setup. Integrate WIFI 6 and Bluetooth 5.1 for optimal connectivity. Blue Line's modular design makes it possible to configure fully to specific requirements.

Mobile workstation configured to your needs. Best-in-class ergonomics. Height adjustable



Equip with two HMI/monitors



Option for integrated client

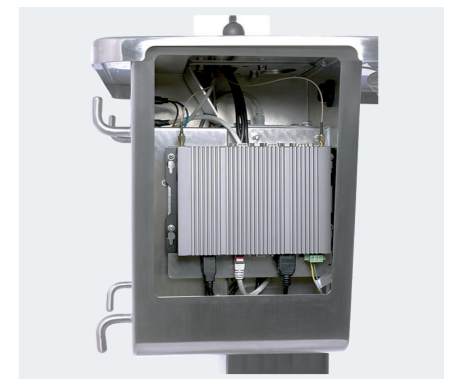

Equip with HMI/monitors with or without keyboard



Rear side of dual screen model



Worksurface configured to fit your requirements for keyboard, mouse and other equipment



Work unplugged for an entire shift and hot swap the batteries for continuous mobility



Cleanroom Tablet

The lightest and thinnest cleanroom tablet ever on the market. Easy-to-clean design with smooth unbroken surfaces. Detergent resistant and operable with gloves.

EVERYBODY GOES MOBILE

Digitization of work processes in the cleanroom is one of the strongest trends in the market. Mobile IT solutions mean both lower acquisition and installation costs, paving the way for the most flexible working methods.

Blue Line's CleanTablet supports dedicated applications and manufacturing execution systems (MES). Perfect for standard operating procedures, quality manuals, and for conducting training and instruction sessions. The tablet is also used for quality assurance through e.g. sampling and cell counting. In addition to this, the Blue Line CleanTablet is ideal for documenting issues in production processes with the built-in camera and video.

CLEANROOM TABLETS FOR DEMANDING ENVIRONMENTS

However, the use of mobile computers and cleanroom tablets in life science, biotech, and pharmaceutical environments introduces several challenges.

Conventional tablets are not designed for daily cleaning with aggressive media, and that may affect both functionality and eventually invalidate the warranty.

Based on Blue Line's industrial know-how and the feedback from our customers, we offer solutions to the market that take care of the typical challenges.

THE BEST USER EXPERIENCE IN THE MARKET

Blue Line's cleanroom tablets are made of high-tech material suitable for biotech and pharmaceutical environments where cleanability and resistance to detergents are essential. Best-in-class ergonomics with low weight, up to 60% lighter and 60% thinner than competing tablets. The high-resolution multi-touch displays are operable with cleanroom gloves or a touch pen for higher precision.

Blue Line offers and continuously expands its CleanTablet ecosystem to optimize digitization and still ensure perfect ergonomics and cleanability in all cleanroom grades.

Achieve greater flexibility and productivity with mobile computers from Blue Line.

Withstands all known detergents. Easy-to-clean design with smooth unbroken surfaces compatible with nitrile and neoprene cleanroom gloves



Compact dimensions and low weight, up to 60% lighter and 60% thinner



10.5" and 13" multi touch display



Touch pen - magnetic and light weight



Add a Cleanroom Hub - the ultimate solution for charging and wired connectivity



Charger for 4 tablets



Go passwordless, contactless, and handsfree

Are you tired of the hassle of regular logins, confirmations, or electronic signatures in your production? With Nymi Band, pharmaceutical manufacturers can save a significant amount of time with this game-changing solution with its innovative biometric security technology.

ENHANCING SECURITY AND EFFICIENCY

Utilizing the contactless and hands-free capabilities of the Nymi Band, a singular authentication method not only enhances security but also significantly improves operational efficiency. This eliminates the need for operators to repetitively input their usernames and passwords or manually apply e-signatures, thereby concurrently mitigating the risk of unauthorized access or security breaches.

SEAMLESS INTEGRATION AND USER EXPERIENCE

The Nymi Band's seamless integration with production systems and its user-friendly interface ensures a smooth transition for your workforce. The intuitive nature of the technology reduces the learning curve, allowing employees to adapt quickly and continue their work with minimal disruption.

PURPOSE-BUILT FOR HIGHLY REGULATED ENVIRONMENTS

The Nymi Band is designed to operate in highly regulated environments, ensuring security, compliance, data integrity, and productivity.

NYMI-READY

Incorporating Blue Line's extensive industrial knowledge and valuable customer input, our pharmaceutical solutions now seamlessly integrate with RFID authentication using Nymi technology. This integration streamlines production, enhances security, and offers compliance-friendly reporting within pharmaceutical manufacturing facilities.



Nymi-Ready integrated reader



Nymi Band



Nymi-Ready integrated reader
Red light turns green when your login is approved



BLUE LINE AND NYMI ARE TECHNOLOGY PARTNERS

Nymi is a leading company in the field of biometric security, providing state-of-the-art authentication solutions. These solutions guarantee data integrity and offer strong security measures, enabling highly regulated industries to uphold compliance while improving productivity.



Our partnership with Nymi aims to leverage their advanced biometric authentication technology to enhance workplace security, compliance, and productivity in highly regulated industries. This collaboration signifies a step towards creating a more secure, controlled, and efficient working environment, emphasizing the future of authentication in life sciences manufacturing and the connected worker experience.

Product overview

HMIs, Mobile Operator Stations and Tablets for cleanroom and hygienic production. Blue Line's modular design makes it possible to configure to specific needs in functionality, finish and environment.

HMI SYSTEMS FOR FIXED MOUNTING

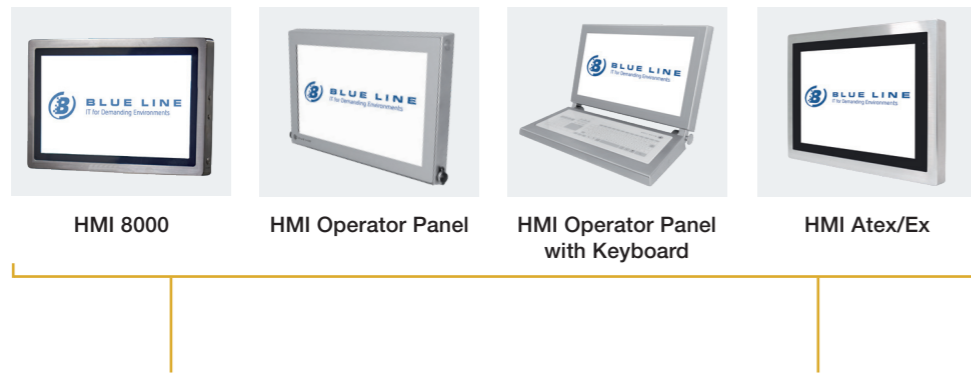

MOUNTING SYSTEMS



Examples of mounting systems
Further options available

DESKTOP WORKSTATION



Examples of desktop systems
Further options available

MOBILE OPERATOR STATIONS



HMI SYSTEMS FOR IN-WALL MOUNTING AND INTEGRATION



Examples of integration
Further options available

CLEANROOM TABLETS



CleanTablet



Cleanroom Hub Charger for 4 tablets Keyboard and Mouse

Product specifications

HMI

PRODUCT	HMI - 8000 SERIES	HMI OPERATOR PANEL	HMI WITH KEYBOARD - OPERATOR PANEL
---------	-------------------	--------------------	------------------------------------



Model			
Type	Monitor, Thin Client, Panel PC		
Construction	Fully sealed enclosure in stainless steel AISI 304 or 316L		
Cooling	Fanless		
Ingress Protection	IP66	IP65	
Display	15.6": 1920 x 1080, 16:9, FHD 21.5": 1920 x 1080, 16:9, FHD 24": 1920 x 1080, 16:9, FHD	21.5": 1920 x 1080, 16:9, FHD	
Touch Type	Projected capacitive multi touch (support gloves) No touch (optional) Optical bonding (optional)	Projected capacitive multi touch (support gloves)	
Monitor			
I/O	1 x 3pin DC power, 1 x USB 2.0, 1 x HDMI, 1 x M4 ground screw	1 x Power input, 1 to 4 x USB 2.0, COM ports optional, 1 x HDMI / optional 1 x VGA Nymi ready - integrated reader	
Thin Client			
	ThinManager, Microsoft Remote Desktop (RPD), NoTouch OS, VNC, Citrix, VMware and others		
Panel PC			
Processor and RAM	Intel Celeron N2930: 1.83GHz, 4/8GB Intel Celeron J6412: 2.6GHz, max 32GB Intel Core i3-8145UE: 3.9GHz, max 64GB Intel Core i5-8365UE: 4.1GHz, max 64GB	Intel Atom E3845: 1.9GHz, 4/8GB Intel Celeron J6412: 2.6GHz, max 32GB Intel Core i5-8365UE: 4.1GHz, max 32GB	
I/O	1 x DC power, 1 x Gbe LAN, 2 x USB 2.0	1 x Power input, 1 x Gbe LAN (2 x LAN optional), 1 to 4 x USB ports, COM ports optional Nymi ready - integrated reader	
Expansion		WiFi/Bluetooth (optional)	
Operating System	Supports Windows 10 / 11* Supports Linux *Celeron N2930 don't support Windows 11	Windows 10 / 11* Windows 10 / 11* IoT Enterprise Linux *(Intel Atom E3845 CPU do not support Windows 11)	
Storage	1 x 2.5" SSD		
Keyboard		Touch keyboard or Membrane keyboard	
Power Supply	+9V to +36V DC-input	+90 to +264V AC-input Option +10V to +36V DC-input	
Power Consumption	Max 42W	Max 40W	
Dimension and Weight	15.6": H 290 x W 440 x D 55mm, app. 7.2kg 21.5": H 362 x W 571 x D 55mm, app. 10kg 24": H 423 x W 656 x D 53mm, app. 12.6kg	21.5": H 358 x W 567 x D 50mm, app. 12.3kg	21.5": H 364 x W 573 x D 323mm, app. 18.2kg
Certification	CE / FCC CLASS A	CE / FCC CLASS A	
Mounting	VESA 100 (I/O ports in center) Stainless steel supporting arm Stainless steel tube mount Stainless steel desktop stand Stainless steel yoke mount	VESA 100 (I/O ports in center) Stainless steel supporting arm Stainless steel tube mount Stainless steel desktop stand	
Warranty and After Sales Support	Standard 1 year (option for 3 years)		

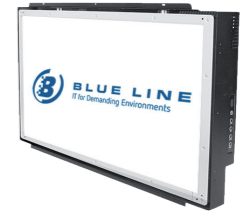

HMI IN-WALL

PRODUCT	HMI OPERATOR PANEL IN-WALL	HMI FOR INTEGRATION
---------	----------------------------	---------------------



Model		
Type	Monitor, Thin Client, Panel PC	
Construction	Fully sealed enclosure in stainless steel AISI 304 or 316L	
Cooling	Fanless	
Ingress Protection	IP65	Front IP65 with sealing
Display	21.5": 1920 x 1080, 16:9, FHD	Sizes ranging from 5.7" to 85" with resolution from 640 x 480 and up to 3840 x 2160
Touch Type	Projected capacitive multi touch (support gloves)	Projected capacitive multi touch (support gloves) No touch from 5.7" up to 24" (optional) Resistive touch (optional) Optical bonding (optional)
Monitor		
I/O	1 x HDMI / optional 1 x VGA 1 to 4 x USB 2.0 ports COM ports optional 1 x power input Nymi ready - integrated reader	1 x VGA Optional display port / DVI / HDMI 1 x USB 2.0 touch OSD control panel 1 x power input
Thin Client		
	ThinManager, Microsoft Remote Desktop (RPD), NoTouch OS, VNC, Citrix, VMware and others	
Panel PC		
Processor and RAM	Intel Atom Bay Trail E3845, 1.9GHz, 4/8GB Intel Celeron J6412, 2.6GHz, max 32GB	
I/O	1 x Gbe LAN (2 x LAN optional) 1 to 4 x USB 2.0 ports, COM ports optional 1 x Power input Nymi ready - integrated reader	
Expansion	1 x MiniPCIe slot (internal)	
Operating System	Windows 7 / 8 / 10 / 11* Windows Embedded 7 / 8 Windows 10 / 11 IoT Enterprise Linux *(Intel Atom E3845 CPU do not support Windows 11)	
Storage	1 x 2.5" SSD	
Power Supply	+90 to +264V AC-input Option +10V to +36V DC-input	
Power Consumption	Max 40W	
Dimension and Weight	21.5": H 411 x W 588 x D 79mm, app. 13kg Slim version: H 406 x W 557 x D 52mm, app. 10kg	
Certification	CE / FCC CLASS A	
Mounting	In-wall / panel mount	In-wall / rear mount
Warranty and After Sales Support	Standard 1 year (option for 3 years)	



HMI ATEX-EX

PRODUCT	ATEX-EX HMI MONITOR 7000 SERIES		ATEX-EX HMI PANEL PC 7000 SERIES	
				
Model				
Type	Monitor, Thin Client, Panel PC			
Construction	Fully sealed enclosure in stainless steel AISI 316L			
Cooling	Fanless			
Ingress Protection	IP66			
Display	15": 1024 x 768, 4:3, XGA, 15.6": 1920 x 1080, 16:9, FHD, 19": 1280 x 1024, 5:4, SXGA, 21.5": 1920 x 1080, 16:9, FHD			
Touch Type	Projected capacitive multi touch (support gloves)			
Monitor				
I/O	1 x M12 12pin for VGA with waterproof cap 1 x M12 USB for touch control with waterproof cap 1 x M12 3pin DC power with waterproof cap External OSD BOX design with M12 3M OSD cable with waterproof cap			
Thin Client	ThinManager, Microsoft Remote Desktop (RPD), NoTouch OS, VNC, Citrix, VMware and others			
Panel PC				
Processor and RAM	Intel Celeron N2930: 1.83GHz, 8GB, Intel Core i5-6300U: 2.4GHz, 4GB to 16GB			
I/O	1 x M12 8pin for 2 x USB 2.0 with waterproof cap 1 x M12 8pin for COM1 / RS-232/422/485 (default RS-232) with waterproof cap 1 x M12 8pin for LAN with waterproof cap 1 x M12 3pin for DC power with waterproof cap			
Expansion	WiFi/Bluetooth (optional)			
Operating System	Windows 7 / 8 / 10 Windows Embedded Standard 7 / 8 Windows 10 IoT Enterprise Linux			
Storage	1 x 2.5" SATA HDD / SSD, 1 x mSATA, 1 x Internal SD Card			
Power Supply	+9V to +36V DC-in by M12 3-pin			
Power Consumption	15": max 21.6W, 15.6": max 13W, 19": max 17W, 21.5": max 19W		15": max 60W, 15.6": max 54W, 19": max 54W, 21.5": max 52W	
Dimension and Weight	15": H 324 x W 399 x D 70mm, app. 8.5kg 15.6": H 290 x W 440 x D 75mm, app. 9.1kg 19": H 388.6 x W 470 x D 75mm, app. 12kg 21.5": H 362 x W 571 x D 75.1mm, app. 13.3kg		15": H 324 x W 399 x D 70mm, app. 9.8kg 15.6": H 290 x W 440 x D 75mm, app. 10.5kg 19": H 388.6 x W 470 x D 75mm, app. 13.4kg 21.5": H 362 x W 571 x D 75.1mm, app. 12.6kg	
Certification	ATEX Zone2 Ex nA ic IIC T4 Gc ATEX Zone22 Ex tc IIC T135°C Dc EN 60079-0:2012/A11:2013, EN 60079-11:2012, EN 60079-15:2010, EN 60079-31:2014, EN 60079-0:2018 CE/FCC Class A CSA Std. C22.2 No213-1987 Class I, Division2, Groups A-B-C-D, T4 Class II, Division2, Groups F-G, T135°C Class III ANSI/ISA 12.12.01-2013			
Mounting	VESA 100 and Panel mount			
Warranty and After Sales Support	Standard 1 year (option for 3 years)			

CLEANROOM TABLET

PRODUCT	CLEANROOM TABLET CLEANTABLET	
		
Model		
Type	Cleanroom Tablet	
Construction	Detergent resistant engineering polymer casing	
Ingress Protection	IP65	
Display	10.5": 1920 x 1280	13": 2880 x 1920
Touch Type	Projected capacitive multi touch operable with gloves Tested with up to 3 layers of nitrile and neoprene cleanroom gloves	
I/O	1 x WiFi 6 1 x Bluetooth 5.1 1 x Interface for charging (included) and USB A connectivity (via optional cable) 1 x 5.0MP front-facing camera with 1080p FHD video 1 x 8.0MP rear-facing autofocus camera with 1080p FHD video	
Hardware Configuration	Model 5-105 (10.5") Processor: Intel Core i3 processor RAM: 8GB Storage: SSD 128GB	Model 22-13 (13") Processor: Intel Core i5 processor RAM: 8GB Storage: SSD 256GB Model 21-13 (13") Processor: Intel Core i5 processor RAM: 16GB Storage: SSD 256GB Model 23-13 (13") Processor: Intel Core i5 processor RAM: 8GB Storage: SSD 256GB Nymi ready - integrated reader Model 24-13 Processor: Intel Core i5 processor RAM: 16GB Storage: SSD 256GB Nymi ready - integrated reader
Graphic Controller	10.5": Intel UHD Graphics 615	13": Intel Iris Xe Graphics
Operating System	Windows 11 Pro	
Power Supply	AC adapter including 1 meter cable for magnetic connector	
Dimension and Weight	10.5": H 209 x W 284 x D 10.7mm, 0.770kg	13": H 245 x W 327 x D 11mm, 1.20kg
Accessories Included	AC adapter including 1 meter cable for magnetic connector	
Accessories Optional	Data cable for USB-A connectivity - Magnetic to 1x USB-A female adaptor 10cm cable Holder for desktop, wall or supporting arm - stainless steel 316L Touch pen - magnetic and light weight including rubber tip Rubber tip - replacement kit for touch pen, 3 pcs Barcode scanner connectable via Bluetooth Cleanroom Bluetooth Keyboard Cleanroom Hub Charger for 4 tablets	
Warranty and After Sales Support	Standard 1 year (option for 2 years)	

MOBILE OPERATOR STATION

PRODUCT	MOBILE OPERATOR STATION T500	MOBILE OPERATOR STATION T1000	MOBILE OPERATOR STATION T3000
			
Model	Mobile Operator Station		
Type	Mobile Operator Station		
Construction	Compact laminate	Mostly stainless steel AISI 304 and partly painted surfaces	Acid resistant stainless steel AISI 316L
Cooling	Fanless		
Ingress Protection	Wipe down cleaning IPA 70% and damp cloth		IP65
HMI	Equipable with one or two displays, either as monitor and separate client or as HMI with integrated pc	Equipable with one or two displays, either as monitor and separate client or as HMI with integrated pc	Equipable with one or two displays, either as monitor and separate client or as HMI with integrated pc Swivel and tilt optional
I/O	Configuration depending on build-in client/pc	Configuration depending on build-in client/pc	Configuration depending on build-in client/pc GbE LAN 2 x USB 2.0 (option for 5 x USB)
Communication	Optional configuration depending on build-in client/pc	Optional configuration depending on build-in client/pc Optional integration for WIFI and Bluetooth including antenna	Optional configuration depending on build-in client/pc Optional integration for WIFI and Bluetooth including antenna
Power	Powered either by 100-240V AC or the integrated battery The integrated battery has a capacity of 500Wh Battery status indicator - LCD display with remaining battery time	T1000 is powered either by 100-240V AC or integrated batteries Batteries charge by internal charger when T1000 is plugged to AC or by external battery charger (optional) Configurable with 2 batteries with a total capacity up to 400Wh Each battery has a capacity of 160Wh or 200Wh Standard battery configuration: 2 x 160Wh (total 320Wh) All batteries are hot swappable for continuous 24/7 operation	2 models available. Model 1: powered by 90-264V AC only. Model 2: powered by 90-264V AC or integrated batteries Batteries charge by internal charger when T3000 is plugged to AC or by external battery charger Configurable with 2 batteries with a total capacity up to 400Wh Each battery has a capacity of 160Wh or 200Wh Standard battery configuration: 2 x 160Wh (total 320Wh) All batteries are hot swappable for continuous 24/7 operation Battery status indicator - LCD display with remaining battery time
Work Surface	Polyrey laminate	Compact laminate	Stainless steel or chemical resistant compact laminate
Hight Adjustment	Fixed height or electric adjustable (table height 83 to 120cm)	Electrical (table height 83 to 116cm)	Electrical height adjustment for seated and standing operation (total height 142 to 170cm)
Casters	4 x anti-static casters - 2 with brakes	4 x anti-static casters - 2 with brakes Option for 4 anti-static casters with brakes	4 x anti-static casters with brakes
Dimension and Weight	H 123 x W 58 x D 62cm Weight 42kg without monitor and thin client	H 122 to 155 x W 55 x D 55cm Weight 47.2kg without batteries and HMI	Max height 170cm Max width 58cm Max depth 69cm Weight 56kg without HMI and batteries 61kg including batteries without HMI
Certification	CE	CE / FCC CLASS A	CE Tested to meet the mechanical stability and safety according to IEC 60601-1 3rd Edition UKCA compliant
Warranty and After Sales Support	Standard 1 year		Standard 1 year (option for 3 years)

KEYBOARD & MOUSE

PRODUCT	CLEANROOM TOUCH KEYBOARD	CLEANROOM MEMBRANE KEYBOARD	CLEANROOM KEYBOARD IN STAINLESS STEEL HOUSING	CLEANROOM BLUETOOTH KEYBOARD
Model	Cleanroom Keyboard			
Type	Cleanroom Touch Keyboard	Cleanroom Membrane Keyboard	Cleanroom Keyboard in Stainless Steel Housing	Cleanroom Bluetooth Keyboard
Construction	Tempered glass front (3mm) in plastic housing	Plastic	Fully sealed enclosure in stainless steel AISI 304 or 316L	Tempered glass front (2mm) in robust ABS housing
Ingress Protection	IP65			IP67
Input Type	Capacitive touch (support gloves)	Membrane keys	Capacitive touch or membrane	
Number of Keys	103	105	103	105
Mouse Function	Capacitive touchpad			
Interface	USB (option for wireless connection)	USB		USB Bluetooth
Operating System	Windows, MacOSX, Linux			
Dimension and Weight	H 22.8 x W 482 x D 179mm, 0.9kg	H 34.9 x W 482.6 x D 184.6mm, 1.3kg	H 50 x W 540 x D 250mm, 6.5kg	H 20 x W 436 x D 160mm, 0.85kg
Warranty and After Sales Support	Standard 1 year (option for 3 years)			

PRODUCT	CLEANROOM LASER MOUSE	WATERPROOF AND DUSTPROOF WIRELESS MOUSE
---------	-----------------------	---



PRODUCT	CLEANROOM LASER MOUSE	WATERPROOF AND DUSTPROOF WIRELESS MOUSE
Model	Cleanroom Mouse	
Type	Cleanroom Laser Mouse	Waterproof and Dustproof Wireless Mouse
Construction	Silicone	Plastic
Ingress Protection	IP68	IP68 (mouse body)
Certification	CE / FCC	
Number of Keys	5	2 + scroll wheel
Interface	USB	USB Wireless 2.4GHz RF technology AES128 encryption
Dimension and Weight	H 37 x W 60 x D 105 mm, app. 170g	H 117 x W 65 x D 37.5 mm, mouse: app. 80 g Charger station: app. 140g
Accessories Included		Charger station
Warranty and After Sales Support	Standard 1 year (option for 3 years)	

Contact our specialists



Blue Line Europe & USA

Michael Asmussen
Business Development
Manager

T: +45 4412 0383
ma@blue-line.com



Blue Line Denmark

Kim Lindberg
Key Account Manager

T: +45 2225 8746
kl@blue-line.com



Blue Line Sweden

Lars Virdeby
Business Development
Manager

T: +46 70 291 97 00
lv@blue-line.com



Blue Line Headquarters

Jørgen Rübner
CTO / Partner

T: +45 4045 8721
jr@blue-line.com



Blue Line Headquarters

Helle Hveisel
Sales and Project
Coordinator

T: +45 8736 8741
hh@blue-line.com



Blue Line Headquarters

Nicolai Pedersen
Inside Sales

T: +45 4880 9751
nrp@blue-line.com

Contact our Headquarters

Blue Line A/S

Kappa 8
8382 Hinnerup
Denmark

T: +45 8678 5000
sales@blue-line.com
www.blue-line.com

Follow us on LinkedIn



BLUE LINE
IT for Demanding Environments